

Line**LIGHT** Fusion

Integrated signalling

With LineLIGHT Fusion, WERMA offers a fully integrable signalling solution that integrates seamlessly into the complete system. The standardised LineLIGHT modules display all machine statuses as functional and integrated design elements. This transfers all the advantages of signalling in terms of safety, efficiency and productivity into the design of the machine.

The fully integrated solution also supports the hygiene requirements of the production environ-

ment. Precise integration into the machine surface minimises dirt edges, avoids openings and offers a high level of protection against the ingress of dust and liquids.

The homogeneous, full-surface illumination of the LineLIGHT Fusion modules ensures optimum visibility and reliably signals hazards or critical machine states.

LineLIGHT Fusion is also available as a segment version. This allows the light pattern to be divided into several sections. With the 200 mm version, either the entire length can be illuminated in a single colour or it can be divided into two 100 mm segments with different colours.

two segments of 150 mm each or three segments of 100 mm each, each of which can also be displayed in different colours.

From a length of 300 mm, up to three segments are possible: continuous illumination over 300 mm,

LineLIGHT Fusion



Technical Specifications			
	100 mm	200 mm	500 mm
Dimension (L x H x W)	145 x 33 x 23 mm	245 x 33 x 23 mm	545 x 33 x 23 mm
Housing	Aluminium, black		
Lens	PC, transparent		
Fixing	Installation mounting		
Protection rating	IP 65		
Connection	M12 5-pin		
Colour options	Red, yellow, green, white, blue, violet, turquoise (Multicolour)		
Tone type	Pulse tone		
Sound Output	85 dB		
Working temperature min./max	-20°C/+50°C		
Voltage	24 V DC		
With acoustic			
Clips	300 100 02	300 100 06	300 100 10
Tape	300 100 04	300 100 08	300 100 12
Current consumption	110 mA	165 mA	325 mA
Without acoustic			
Clips	300 100 01	300 100 05	300 100 09
Tape	300 100 03	300 100 07	300 100 11
Current consumption	100 mA	155 mA	315 mA



Mounting clips

Individual sizes are available on request, in 50 mm increments from 100 to 1000 mm and in 100 mm increments from 1000 to 1500 mm.

LineLIGHT Fusion Segment



Technical Specifications				
	200 mm	300 mm	600 mm	900 mm
Dimension (L x H x W)	245 x 33 x 23 mm	345 x 33 x 23 mm	645 x 33 x 23 mm	945 x 33 x 23 mm
Housing	Aluminium, black			
Lens	PC, transparent			
Fixing	Installation mounting			
Protection rating	IP 65			
Connection	M12 5-pin			
Colour options	Red, yellow, green, white, blue (Multicolour) Colour selection depends on variant			
Tone type	Pulse tone			
Sound Output	85 dB			
Working temperature min./max	-20°C/+50°C			
Voltage	24 V DC			
Number of segments	1-2	1-3	1-3	1-3
With acoustic				
Clips	300 100 66	300 100 68	300 100 70	300 100 72
Current consumption	170 mA	220 mA	380 mA	545 mA
Without acoustic				
Clips	300 100 65	300 100 67	300 100 69	300 100 71
Current consumption	160 mA	210 mA	375 mA	535 mA



Mounting clips

Sizes 1200 and 1500 mm available on request.

Typical application

For machine and plant manufacturers who want to implement a consistent machine design with an integrated signalling solution for signalling machine statuses on

- machines
- automation systems
- assembly systems
- transport and conveyor belts
- AGVs (automated guided vehicles)
- All other industrial products that have a sheet metal housing



Mounting types

- Screw mounting using clips
- Adhesive mounting using industrial adhesive tape

Technical Diagram

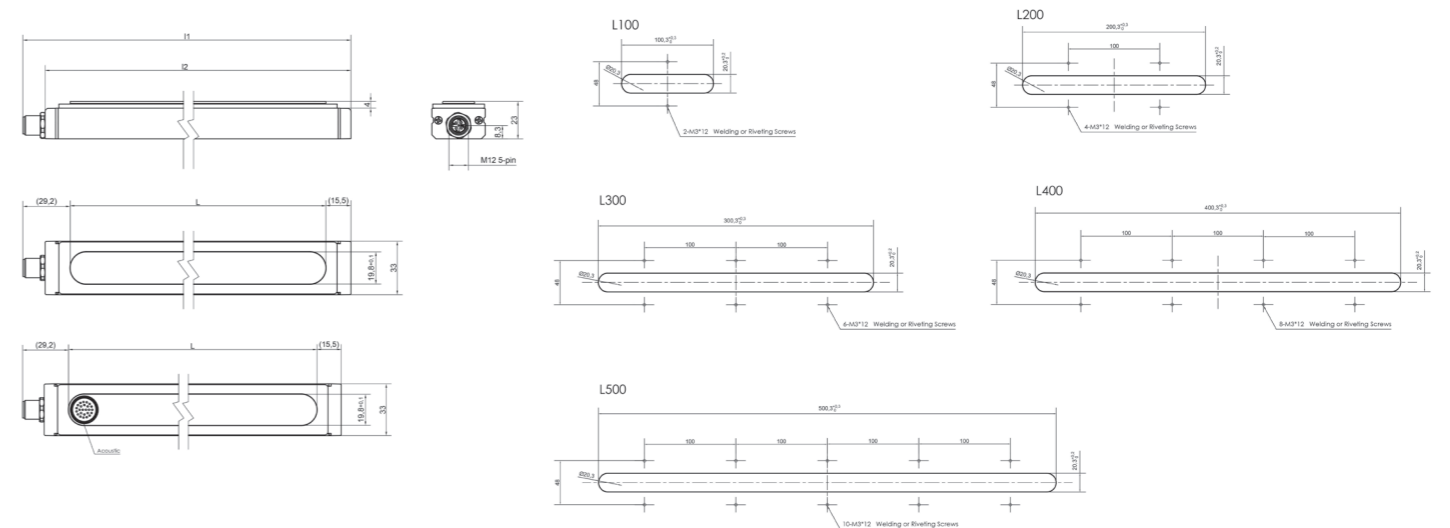

WERMA Signaltechnik GmbH + Co. KG

Dürbheimer Str. 15
D-78604 Rietheim-Weilheim
Phone + 49 (0) 74 24 95 57- 0 | Fax + 49 (0) 74 24 95 57- 44
www.werma.com | info@werma.com

WERMA Signaltechnik

Niederlassung Neuhausen am Rhf.
Rheingoldstrasse 50
8212 Neuhausen am Rheinfall
Switzerland
Phone + 41 (0) 52 674 00 60 | Fax + 41 (0) 52 674 00 66
www.werma.ch | info@werma.ch

WERMA Italia S.r.l.

Via dell'Artigianato 42
29122 Piacenza
Italy
Phone +39 (0) 523 044 544
www.werma.it | info@werma.it

WERMA SARL

56, Rue Colière
69780 Mions
France
Phone + 33 (0) 4 72 22 37 37
www.werma.fr | info@werma.fr

WERMA BENELUX

Poortakkerstraat 41C
9051 Sint-Denijs-Westrem
Belgium
Phone + 32 (9) 220 31 11
www.wermabenelux.com | info@wermabenelux.com

WERMA (UK) Ltd.

13 Brooklands Court
Kettering Venture Park
Kettering NN15 6FDR
Great Britain
Phone + 44 (0) 15 36 48 69 30 | Fax + 44 (0) 15 36 51 48 10
www.werma.co.uk | uksales@werma.co.uk

WERMA USA Inc.

1266 Oakbrook Drive, Suite A
Norcross, GA 30093 USA
Phone +1 (470) 361-0600
www.werma.com | us-info@werma.com

WERMA (Shanghai) Co., Ltd.

Building 8, No. 85, Mingnan Road
Songjiang, Shanghai, P. R. C
201613
Phone +86 (0) 21 /5774-0022 | Fax +86 (0) 21 /5774-6601
www.werma.com.cn | info@werma.com.cn

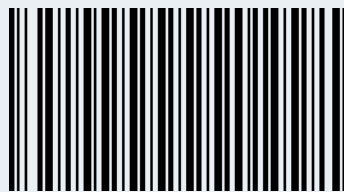

03/25 · 540 000 095 · EN